



PETER CLAASSEN

DUBBELE BEDIENINGEN



Uitbouw handleiding dubbele bediening

Het uitbouwen van een Peheja dubbele bediening is geheel op eigen risico!



So entfernen Sie die Doppelbedienung

Der Ausbau einer Peheja Doppelbedienung erfolgt ausschließlich auf eigenes Risiko!



Uitbouw handleiding dubbele bediening

Het uitbouwen van een PEHEJA dubbele bediening is geheel op eigen risico!

De handleiding is slechts een hulpmiddel en dient als indicatie. Er zijn veel verschillende supplementen en klemmen en die kunnen dan ook afwijken van ten opzichten van de fotos. Wij zijn in geen vorm aansprakelijk voor druk fouten, demontage fout,

Indien u niet begrijpt wat er bedoelt wordt of geen technische kennis heeft. Adviseren wij u het dubbele bediening systeem door ons te laten uitbouwen werkwijze, schades aanvoertuigen etc. De uitbouw is dan ook volledig voor eigen risico



So entfernen Sie die Doppelbedienung

Der Ausbau einer PEHEJA-Doppelsteuerung erfolgt ausschließlich auf eigenes Risiko!

Der Ausbau einer PEHEJA-Doppelsteuerung erfolgt ausschließlich auf eigenes Risiko! Das Handbuch ist lediglich ein Hilfsmittel und dient der Orientierung. Es gibt viele verschiedene Ergänzungen und Klammern und diese können daher von den Fotos abweichen. Wir haften in keiner Weise für Druckfehler, Demontagefehler, Arbeitsweisen, Schäden an Fahrzeugen etc.

Wenn Sie nicht verstehen, was gemeint ist oder keine technischen Kenntnisse haben. Wir empfehlen Ihnen, das Doppelbedienung von uns ausbauen zu lassen.

Der Ausbau erfolgt daher ausschließlich auf eigenes Risiko





 Start situatie linker zijden

 Ausgangssituation linke Seite





 Knip de binnen kabels door

 Schneiden Sie die Innenkabel ab

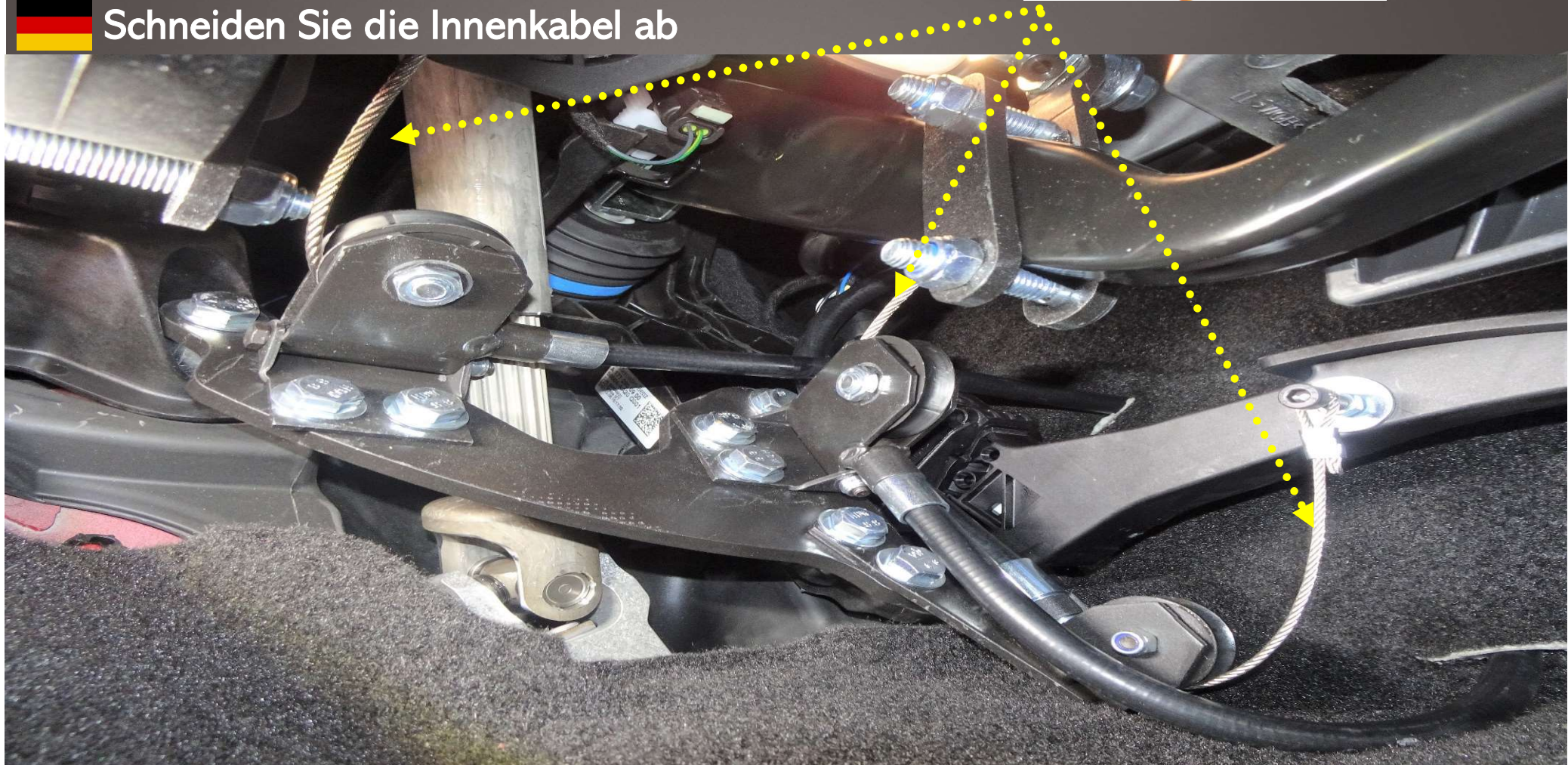



 Verwijder de pedaal klemmen

 Entfernen Sie die Pedalklemmen

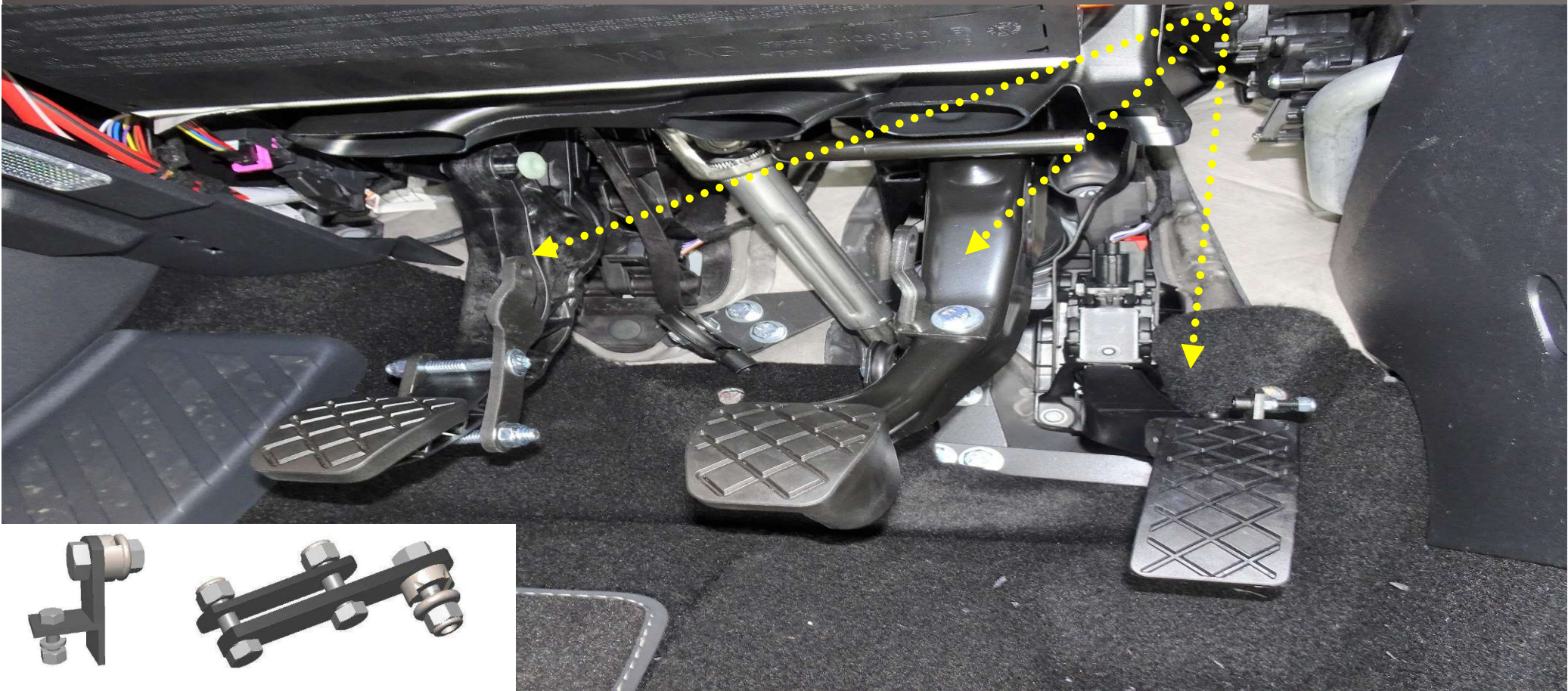



De pedaalklemmen zijn er in verschillende varianten, afhankelijk van het type pedaal



Die Pedalklemmen gibt es je nach Pedaltyp in unterschiedlichen Varianten





 Verwijder de katrollen

 Entfernen Sie die Umlenkrolle

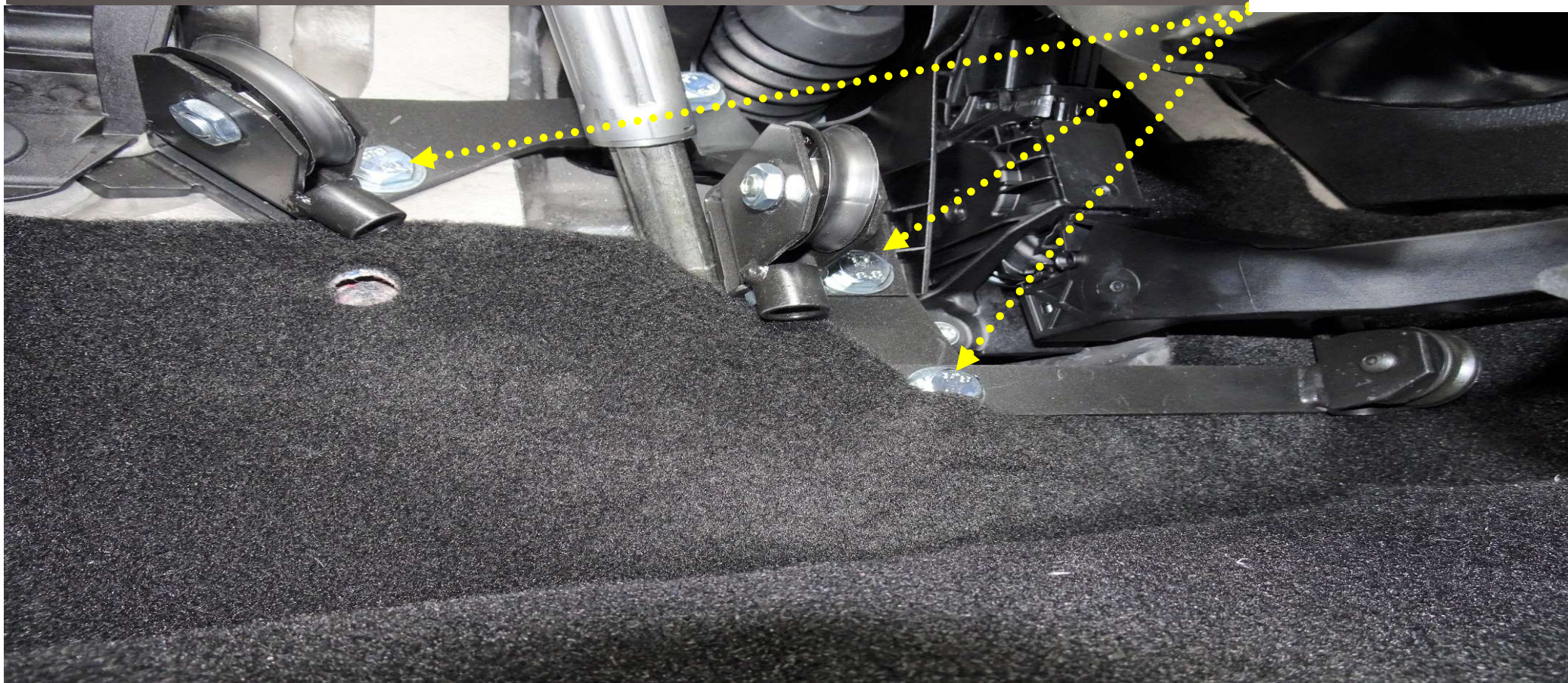



 Verwijder de katrollen

 Entfernen Sie die Umlenkrolle

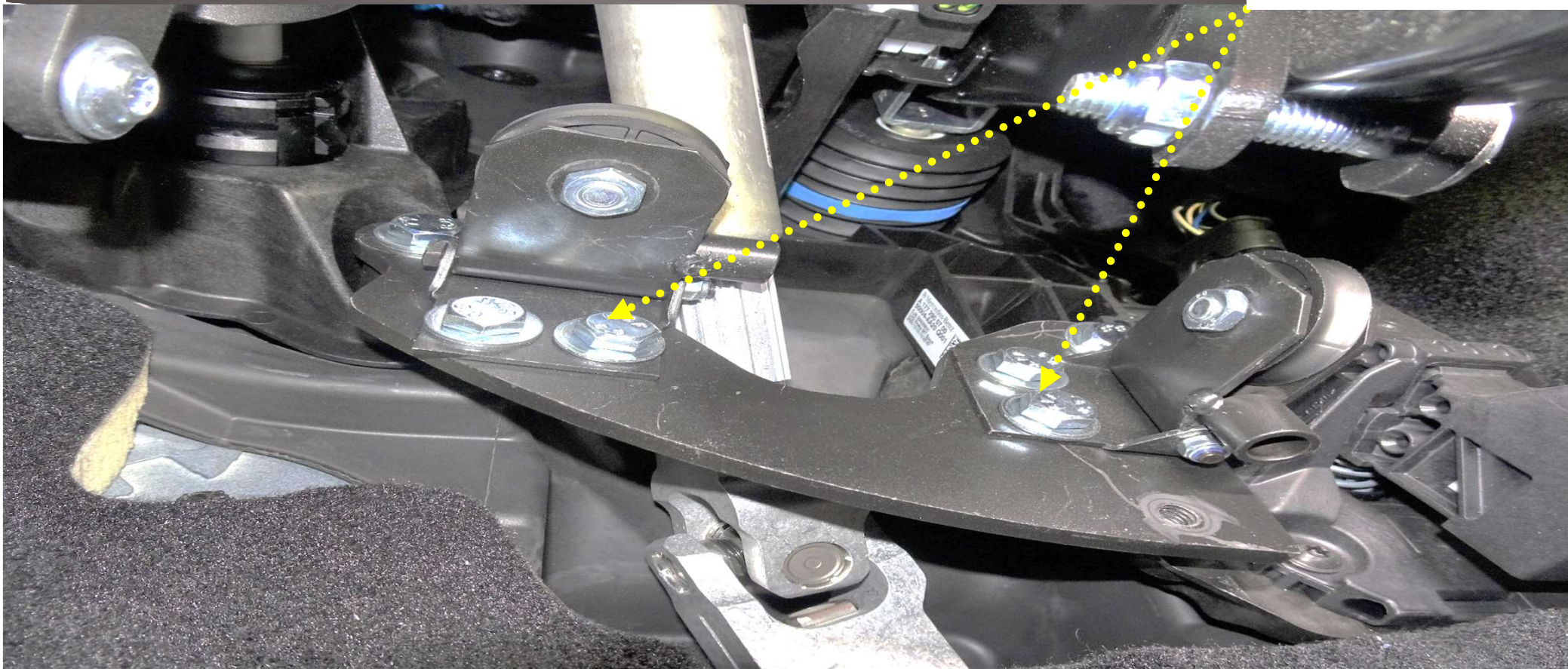



 Verwijder het supplement

 Entfernen Sie die supplement

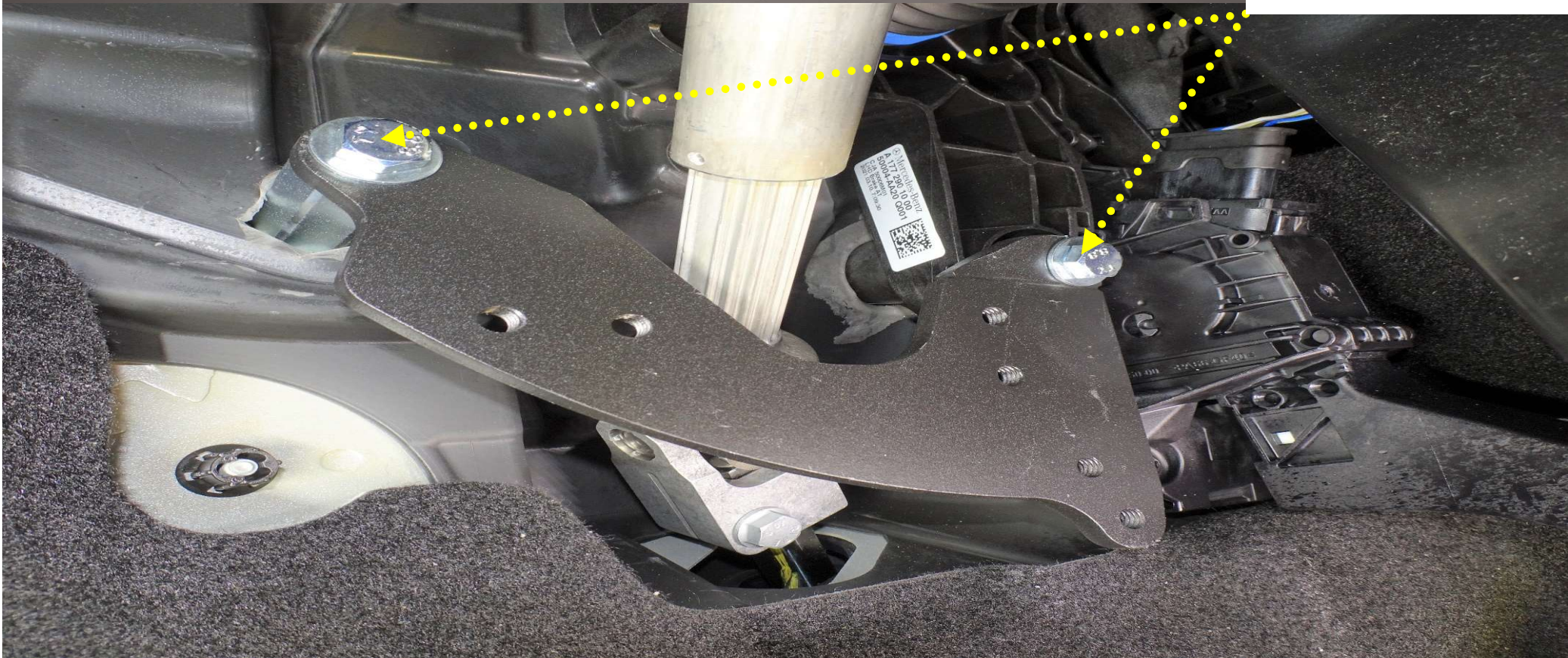



 Verwijder de koperlmoeren

 Entfernen Sie die Verbindungsmutter





 Monteer de moeren

 Montier die Mutter

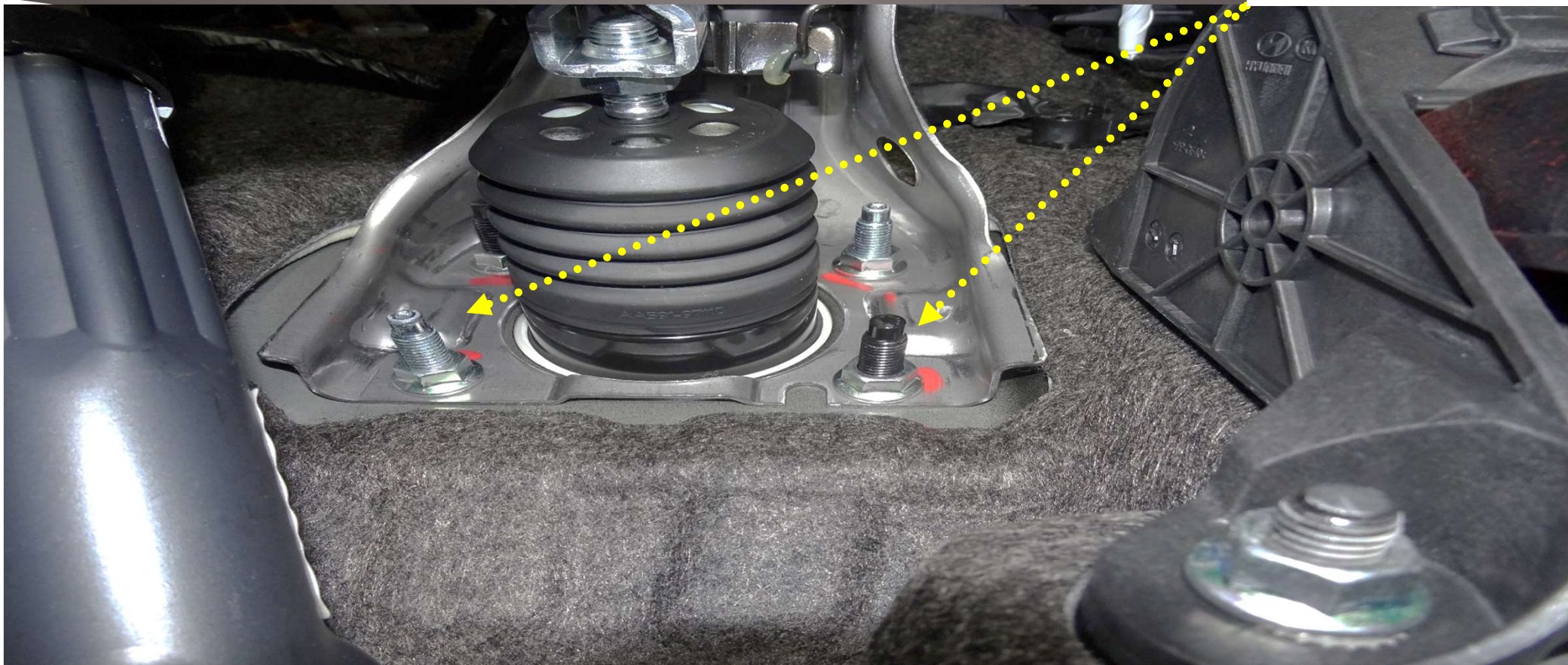





Check na verwijdering van alle onderdelen en dat alle pedalen goed functioneren

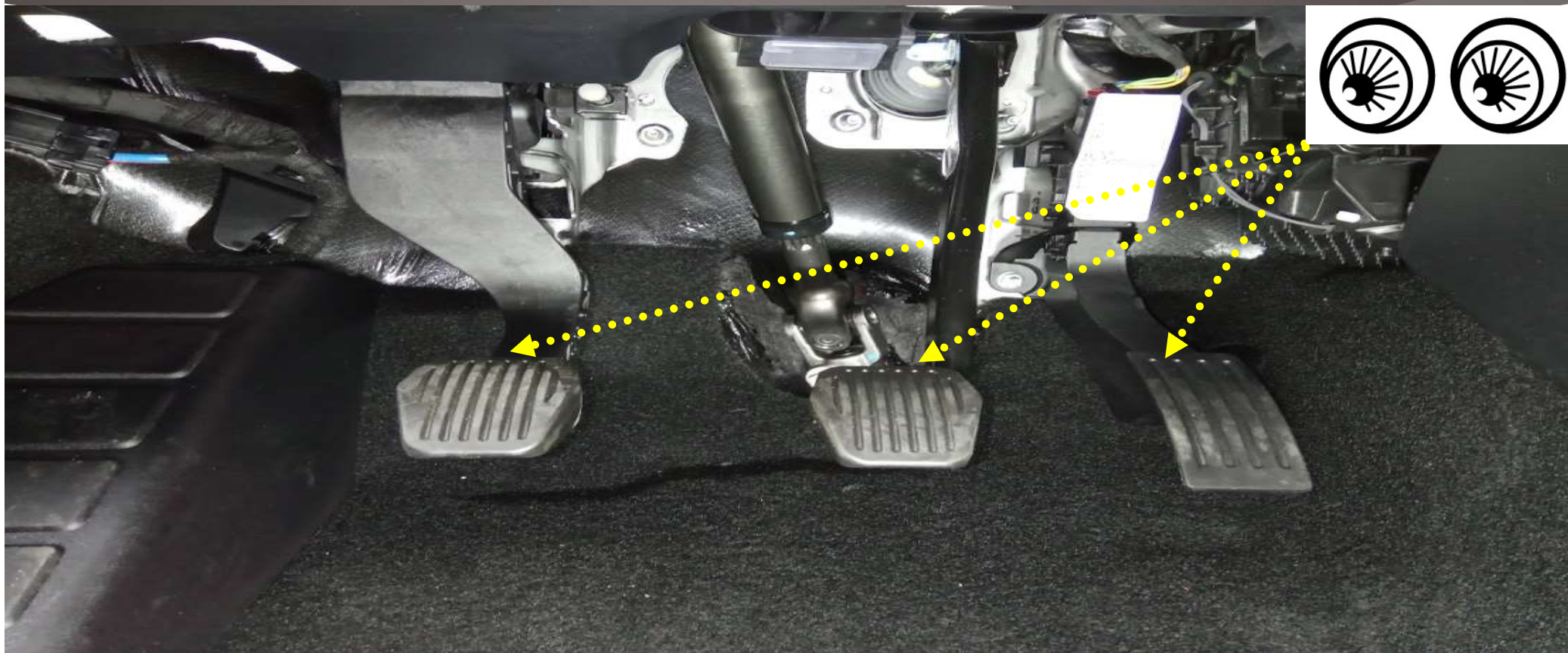

Überprüfen Sie nach dem Entfernen aller Teile, ob alle Pedale ordnungsgemäß funktionieren



 Check of dat er geen materialen bij de kruiskoppeling terecht zijn gekomen van de stuurstang en dat het stuur vrij kan draaien !

 Stellen Sie sicher, dass kein Material in das Kardangelenk der Lenkstange gelangt ist und dass sich das Lenkrad frei drehen lässt!





De volgende onderdelen dient u mee te nemen zodat wij de dubbele bediening weer in kunnen bouwen. Eventueel missende onderdelen zullen in rekening gebracht worden.

1 Linker montage supplement en bijhorend onderdelen

2 katrollen

3 klemmen

This document is copyrighted by Peheja Heusden BV





Damit wir die Doppelbedienung wieder einbauen können, müssen Sie folgende Teile mitbringen.
Eventuell fehlende Teile wird in Rechnung gestellt

1 Linker Montagezusätze / Supplementen und zugehörige Teile

2 Umlenkrolle

3 Klemmer

This document is copyrighted by Peheja Heusden BV

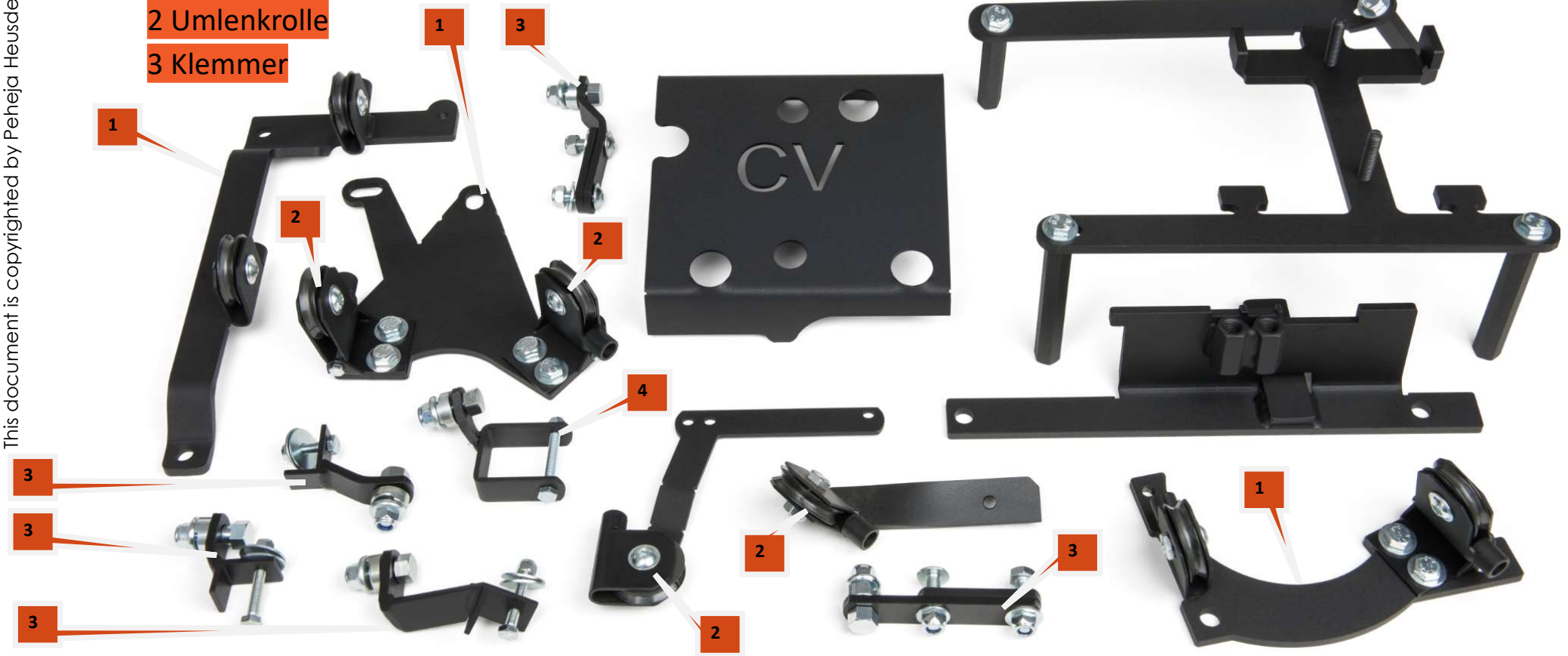



 Start situatie rechter zijden

 Ausgangssituation rechte Seite







 Verwijder de lange M10 bout

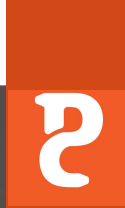

 Entfernen Sie die lange M10-Schraube





 Verwijder de lange M10 bout
 Entfernen Sie die lange M10-Schraube

 In de auto
 Im Auto

 In het motor ruim
 In der Motorraum

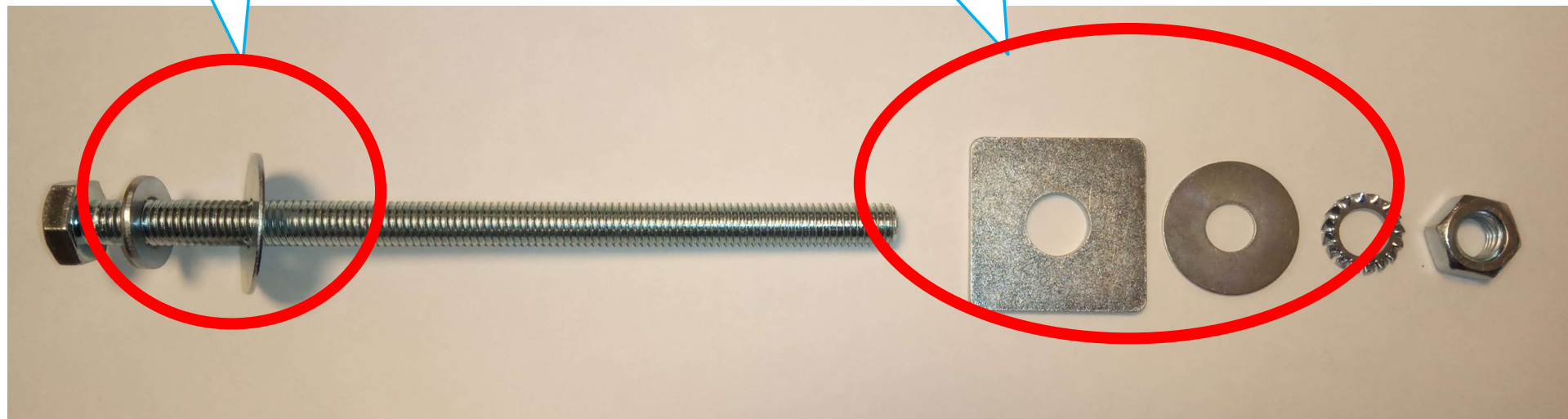



 Verwijder de lange M10 bout
 Entfernen Sie die lange M10-Schraube

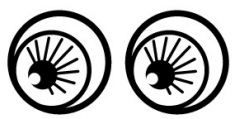

 Verwijder de lange M10 bout
 Entfernen Sie die lange M10-Schraube





 Verwijder de dubbele bedienung
 Entfernen Sie die Doppelbedienung



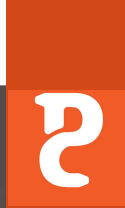

 verwijder het stalen supplement
 Entfernen Sie die Stahlplatte





 Dicht het boor gat af met body kit
 Verschließen Sie das Loch mit Bodykit

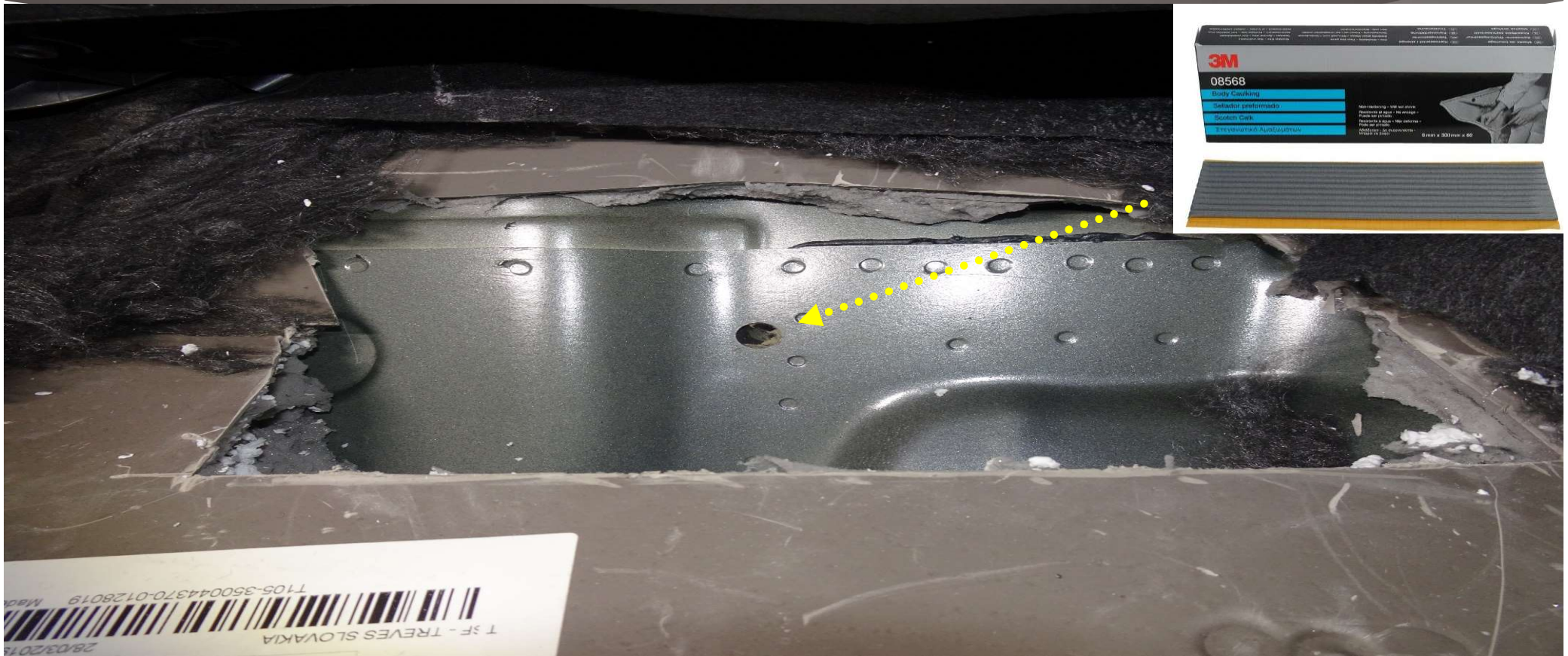



Verwijder de moeren van de afschermplaat



Entfernen Sie die muttern und die Abdeckkappe aus Kunststoff





Verwijder de moeren van de dubbele bediening



Entfernen Sie die muttern von das Doppelbedienung

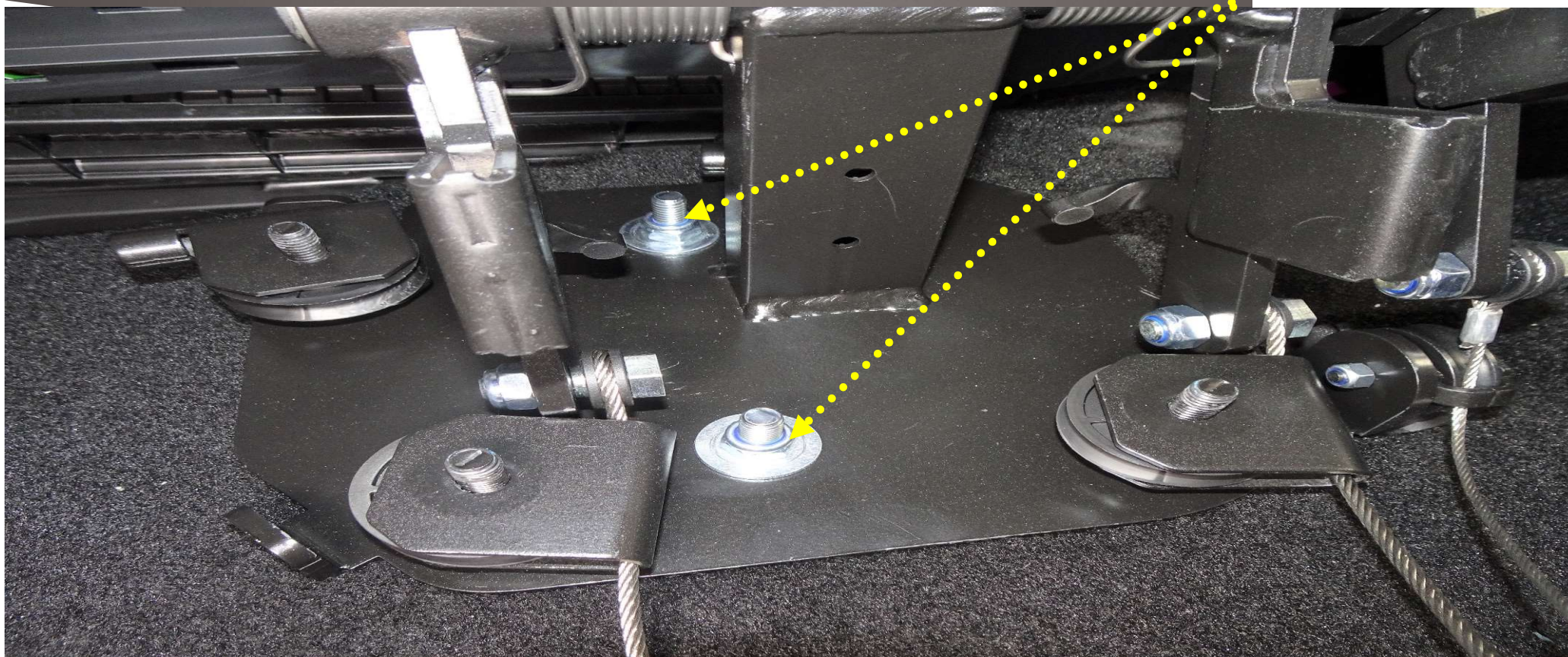



Verwijder het supplement



Entfernen Sie die supplement





Verwijder de koperlmoeren



Entfernen Sie die Verbindungsmutter

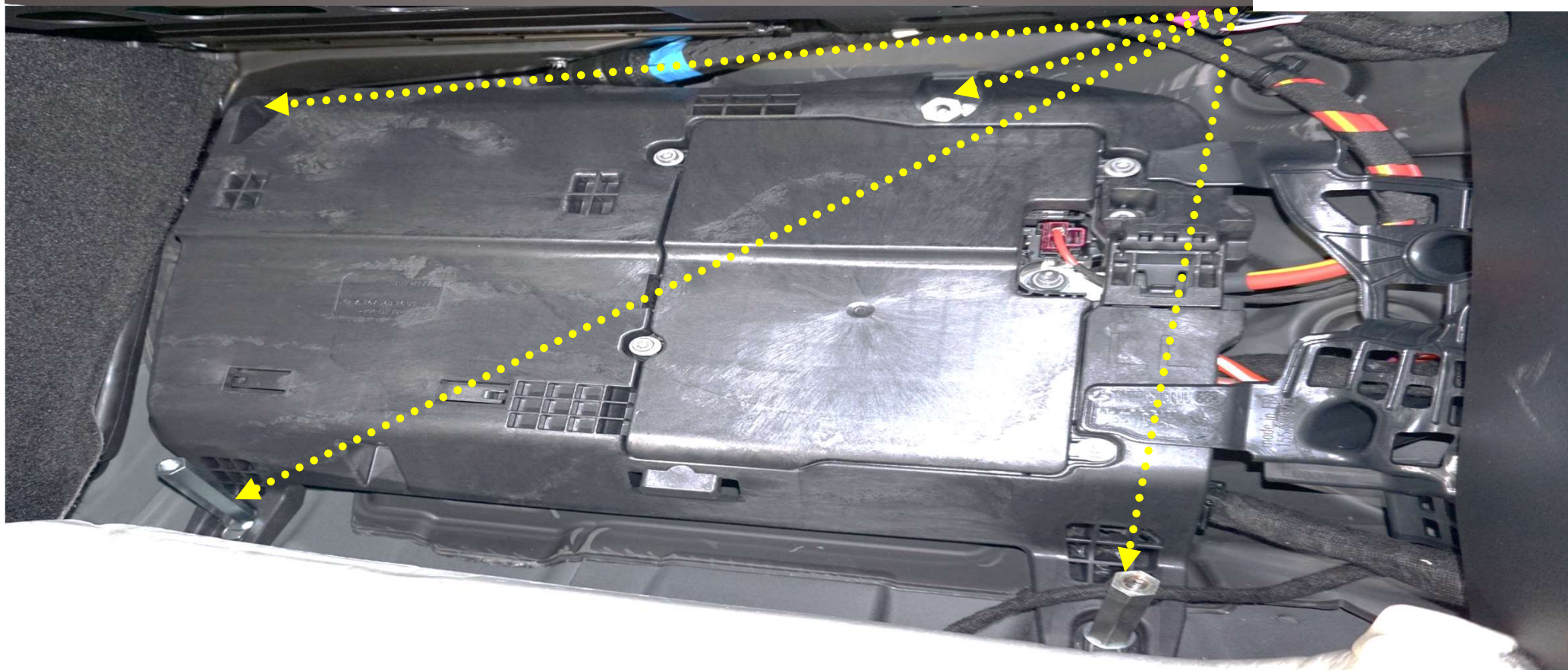



 Monteer de moeren

 Montier die Mutter

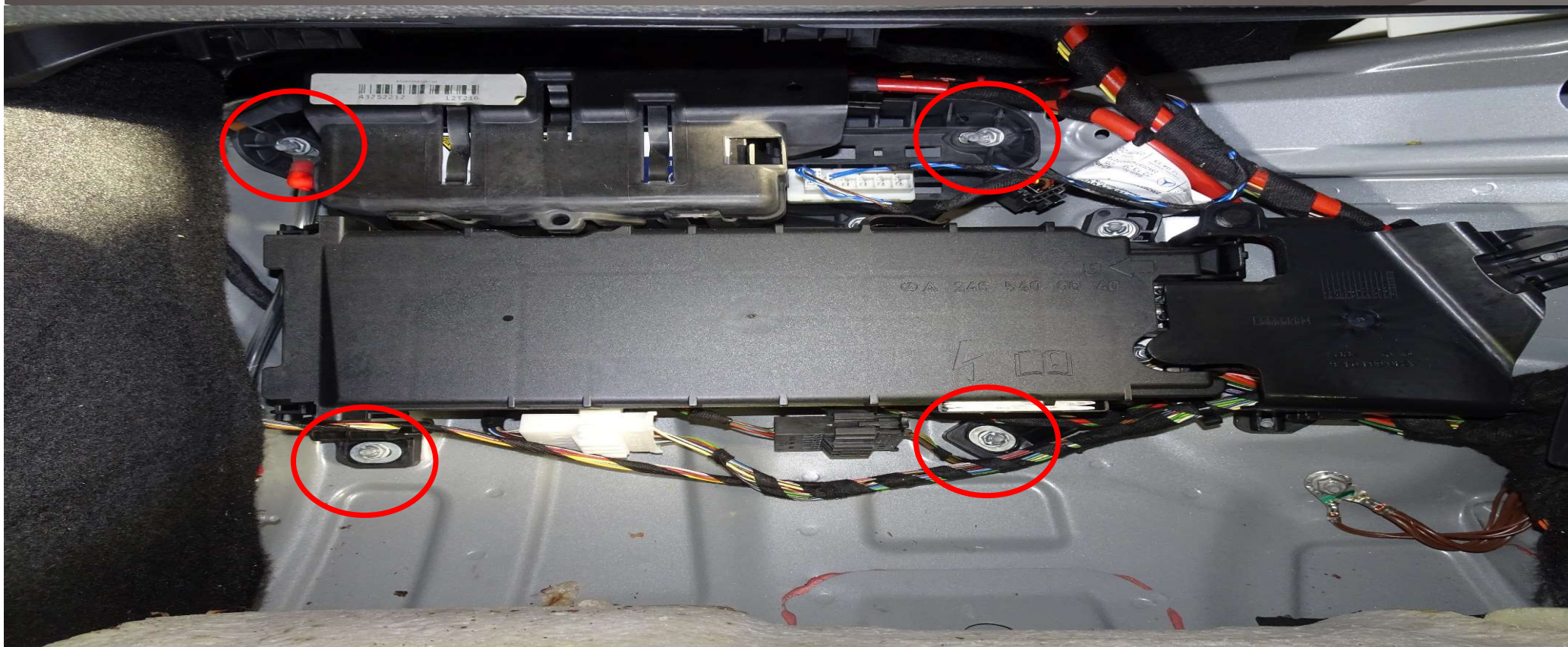

 De volgende onderdelen dient u mee te nemen zodat wij de dubbele bediening weer in kunnen bouwen. Eventueel missende onderdelen zullen in rekening gebracht worden

4 Rechter montage supplement en bijhorend onderdelen

5 Dubbele bediening

6 Elektronica onderdelen



 De volgende onderdelen dient u mee te nemen zodat wij de dubbele bediening weer in kunnen bouwen. Eventueel missende onderdelen zullen in rekening gebracht worden

4 Rechter montage supplement en bijhorend onderdelen

5 Dubbele bediening

6 Elektronica onderdelen





Neem alles mee !!



- ▶ Neem al deze onderdelen mee naar Peter Claassen bv, zodat wij deze weer kunnen hergebruiken voor de installatie. De buiten en binnen kabels worden altijd vernieuwt bij een overbouw. Deze dienen dan ook niet retour genomen te worden.
- ▶ Mocht u vragen hebben of advies wensen, kunt u ons altijd contacteren.
- ▶ Wij kunnen de uitbouw ook verzorgen voor u !! Dit kan u problemen voorkomen. gemiddeld hebben wij 20 minuten nodig voor een uitbouw
- ▶ + 31 (0)416 33 99 73



Damit wir die Doppelbedienung wieder einbauen können, müssen Sie folgende Teile mitbringen.
Eventuell fehlende Teile wird in Rechnung gestellt

- 4 rechte Montagezusätze und zugehörige Teile
- 5 Doppel bedienung
- 6 Elektronikteile





Damit wir die Doppelbedienung wieder einbauen können, müssen Sie folgende Teile mitbringen.
Eventuell fehlende Teile wird in Rechnung gestellt

4 rechte Montagezusätze und zugehörige Teile

5 Doppel bedienung

6 Elektronikteile





Nehmt alles mit!!



- ▶ Nehmen Sie alle diese Teile mit zu Peter Claassen bv, damit wir sie für die Installation wiederverwenden können. Die Außen- und Innenkabel werden bei einem Überhang immer erneuert.
- ▶ Wenn Sie Fragen haben oder Beratung benötigen, können Sie sich jederzeit an uns wenden.
- ▶ Wir können die Doppelbedienung auch für Sie ausbauen, Dies kann Ihnen Probleme ersparen. Im Durchschnitt benötigen wir 20 Minuten, um die Doppelbedienung zu entfernen
- ▶ +31 (0)416 33 99 73



Tekst en uitleg waarom wij producten niet meer inbouwen.



- ▶ **Er zijn verschillende redenen waarom producten niet meer worden ingebouwd**
 - **De producten die tussen 1992 t/m 2008 geleverd zijn voldoen niet meer aan de normen en eisen van huidige tijd. (materialen kwaliteiten, lassen etc)**
 - **Uit testen en onderzoeken is er gebleken dat het product niet voldoet om zo lang mee te gaan en dat er gevaarlijke gebreken kunnen ontstaan zowel aan de bijrijders kant als aan de bestuurders kant door bijvoorbeeld staal vermoeidheid. Vandaar ook dat de nieuwe varianten dubbele bedieningen en supplementen op vele punten zijn aangepast om dit te voorkomen.**
- ▶ **Peheja Heusden BV en onze inbouw dealers moeten zicht aan de TÜV keuring, eisen en normen houden om de kwaliteit en veiligheid te kunnen waarborgen.**
- ▶ **De reden hiervoor is dat er verantwoorde bedrijfsvoering gevoerd moet worden vanuit de Nederlandse wet, (ook al is deze in gebreken omtrent de keuringen van de dubbele bediening in Nederland). In de rest van de Europese landen is deze keuring namelijk wel verplicht. Het is namelijk een veiligheid product.**
- ▶ **Vandaar vragen wij om uw begrip, mocht deze situatie zich voor doen.**



 De dubbele bedieningen worden niet meer ingebouwd door ons als de pedaalhouder recht op de arm is gelast. Zoals foto 1.0

1.0

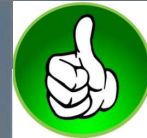

 De dubbele bedieningen worden niet meer ingebouwd door ons als de paal rondom gelast is zoals op foto 2.0

2.0

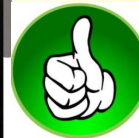

 De dubbele bedieningen worden niet meer ingebouwd door ons als
Katrollen en klemmen er zo uit zien als foto 3.0

